

UNDERFLOOR TO DESK SOLUTIONS

A comprehensive product range of flexible floor to desk cable management and prefabricated wiring systems developed to provide installations that are fast, easy and adaptable for contractor and client.



UNDERFLOOR TO DESK SOLUTIONS

Marshall-Tufflex's underfloor to desk solutions incorporate a range of products for the distribution of power and data services from beneath raised floors and in-screed systems to desks.

A variety of wiring options are available, including the MT32 prefabricated technology that provides seamless connection all the way from the incoming feed to the desktop.

Underfloor to desk solutions provide a sustainable wiring option, offering zero waste systems which can be re-used and re-configured.

Powertrack

Standard and CE (Clean Earth) 63Amp powertrack.



Page
6

Raised floor boxes and grommets

3 and 4 compartment unwired and pre-wired boxes and grommets.



Page
8

In-screed system

PVC-U or steel ducting with 3 and 4 compartment outlet boxes.



Page
11

Faceplates and accessories

Accessories and accessory mounting plates for raised floor and in-screed floor outlet boxes.

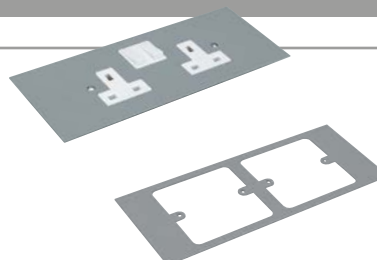

Page
14

MT32 pre-wired underfloor power distribution

A 32Amp, interconnecting, fast-fit and flexible, pre-wired and tested underfloor to floor outlet box power distribution system.

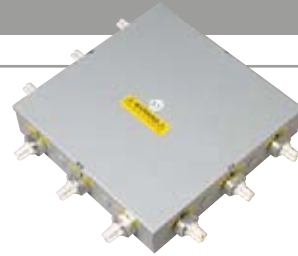

Page 12

Power and data modules

A range of moulded pre-wired and assembled power units that can be used singly or linked by plug and play cable connectors.



Page 17

PowerPosts

An efficient way of managing services at island locations.



Other pre-wired units

For other pre-wired units made to order to suit your specifications, please contact the Technical Team on +44 (0)1424 856688.



A selection of design layouts incorporating MT32 pre-wired technology and powertrack.

Please note: All products should be installed as per the manufacturer's installation instructions and as per current Wiring Regulations

UNDERFLOOR TO DESK SOLUTIONS

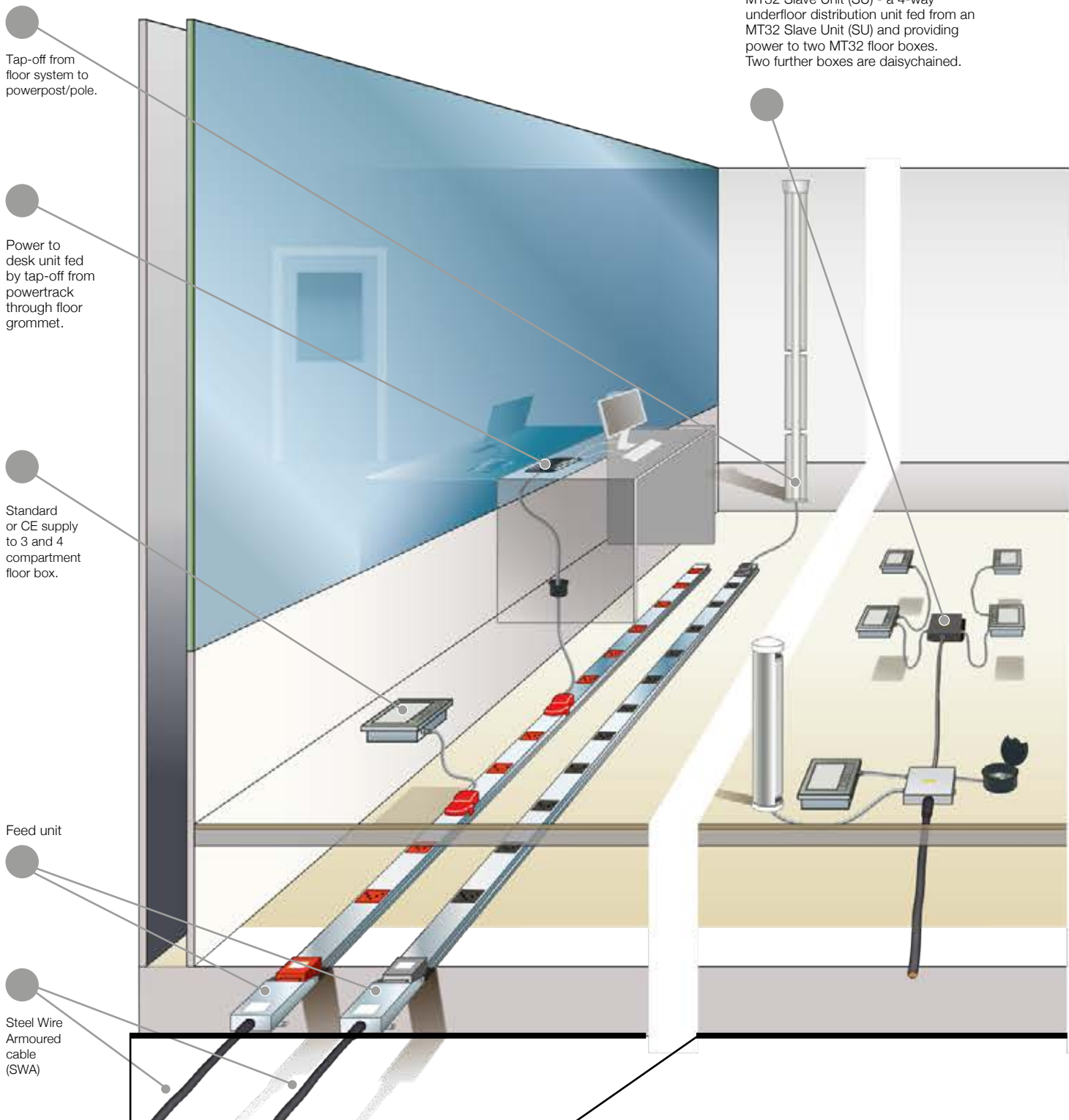

MT32 Slave Unit (SU) - a 4-way underfloor distribution unit fed from an MT32 Slave Unit (SU) and providing power to two MT32 floor boxes. Two further boxes are daisy-chained.

AREA 1

Using traditional powertrack and hard-wired floor boxes

- Standard and Clean Earth (CE) Powertrack
- 63Amp rating

AREA 2 – MT32 PRE-WIRED AND RECONFIGURABLE INTERCONNECTING SYSTEMS

Using MT32 Slave Unit (SU)

- Radial or daisy chain options for Standard and CE Systems
- 32Amp rating

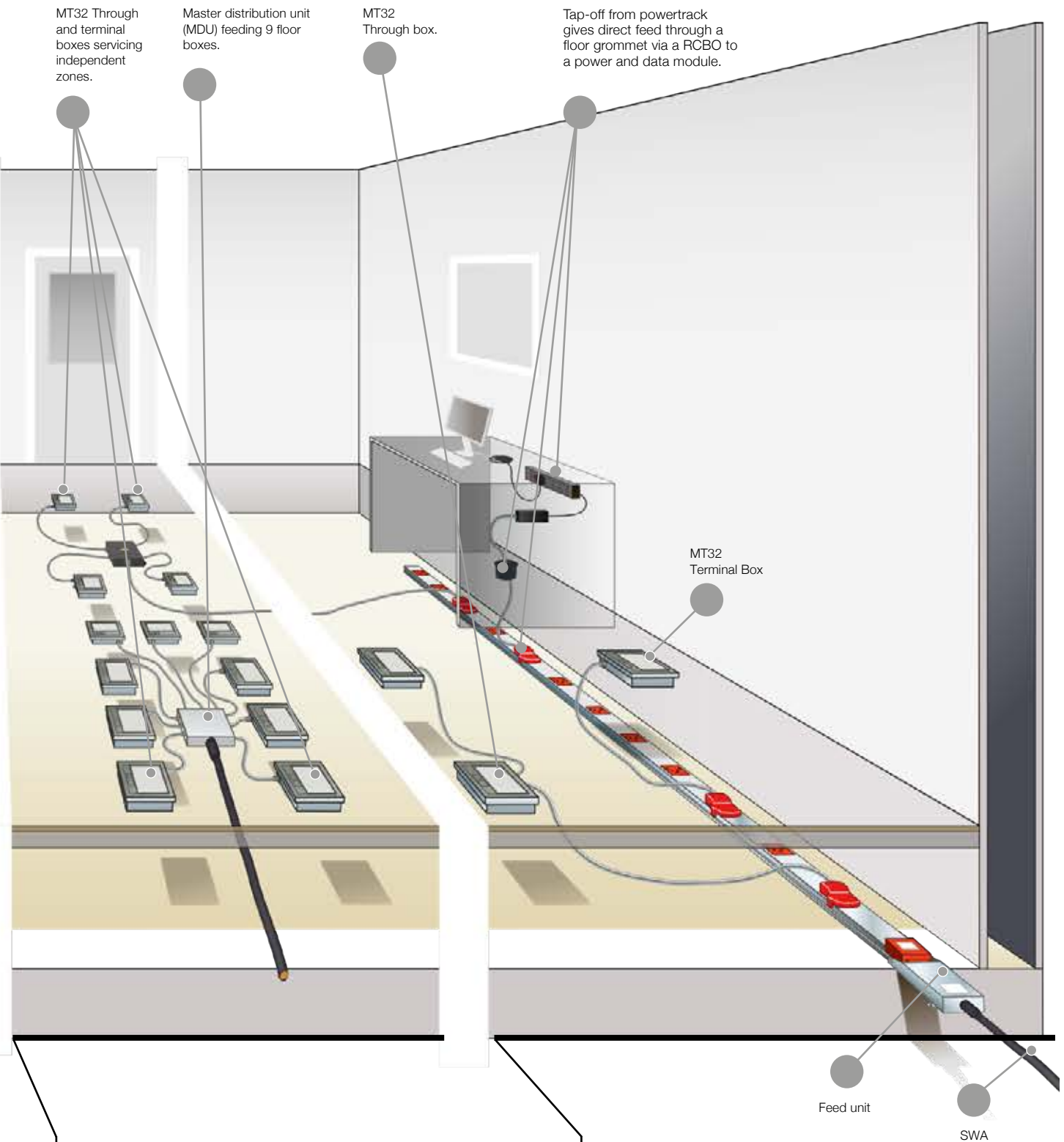

AREA 3 – MT32 PRE-WIRED AND RECONFIGURABLE INTERCONNECTING SYSTEMS

Using MT32 Slave Unit (SU)

- Radial or daisy chain options for Standard and CE Systems 32Amp rating

AREA 4 – A COMBINATION OF powertrack AND MT32

Using 63Amp Standard or CE Powertrack with the MT32 32Amp Underfloor Distribution system.

- A combination that permits greater floor coverage 32Amp rating

A range of 63Amp powertrack complete with integral mounting brackets and pre-assembled end caps and couplers for ease of installation.



Product information

- Each length of track comes complete with pre-assembled coupler, end cap and floor mounting brackets.
- Maximum 63Amp rating
- Tap-offs are key and colour coded for Standard and CE (Clean Earth)
- Tap-offs are 32Amp rated or fused at 13Amp
- Adhesive dust covers protect outlets
- Compatible with MT32 pre-wired floor boxes



Powertrack and fittings are independently tested by Intertek

Identification	
Standard	CE
Standard: Grey CE (Clean Earth): Red	

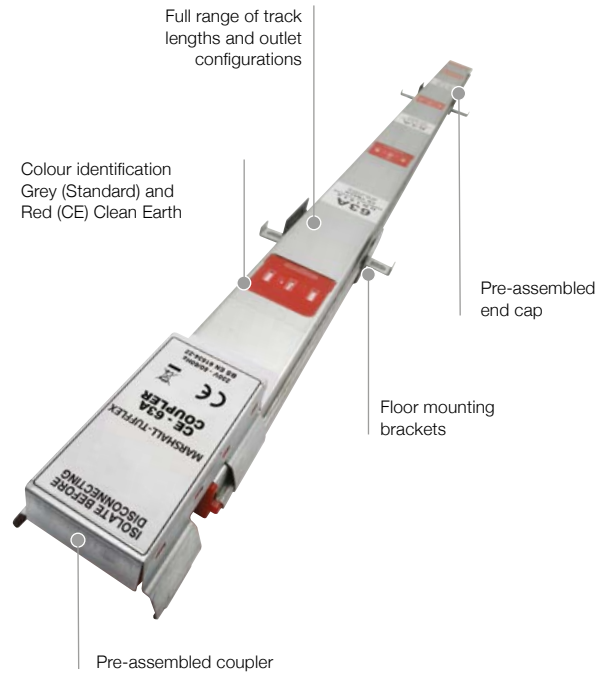

To calculate powertrack lengths required for different floor layouts refer to table on opposite page.

UNDERFLOOR TO DESK SOLUTIONS

Powertrack
Standard



code	length	Number of outlets	pitch (mm)	pack
UN1112	1.2m	4	300	2
UN1118	1.8m	6	300	2
UN1114	2.4m	8	300	2
UN1116	3.6m	12	300	2

Powertrack
CE (Clean Earth)



code	length	Number of outlets	pitch (mm)	pack
UN1212	1.2m	4	300	2
UN1218	1.8m	6	300	2
UN1214	2.4m	8	300	2
UN1216	3.6m	12	300	2



Standard
Rated current 63Amp



Low Noise (CE)
Rated current 63Amp



Feed unit	Interlink	Interlink	Tap-off units	Tap-off units	Tap-off units	Tap-off units
Female	Length 1.2m	Length 2.4m	Unfused 32Amp	Fused 13Amp	Unfused 32Amp	Fused 13Amp
Pack 1	Pack 1	Pack 1	Length 3m	Length 3m	Length 5m	Length 5m
			Pack 1	Pack 1	Pack 1	Pack 1
UN3100	UN5102	UN5104	UN7113	UN7123	UN7115	UN7125
UN3200	UN5202	UN5204	UN7213	UN7223	UN7215	UN7225

Other configurations of tap-off units including fuse options and conduit lengths up to 10m are available on request.

All tap-off units comply with 17th Edition Wiring Regulations Section 543 (High Integrity Earthing).

Powertrack – run length component chart

To determine the number and size of track required for a given area, select your total run length (in metres) from the left hand column, then find the correct track combinations along that row.

Total run in metres	Track lengths required			
3.6	3.6			
4.2	1.8	2.4		
4.8	2.4	2.4		
5.4	3.6	1.8		
6.0	3.6	2.4		
6.6	2.4	2.4	1.8	
7.2	3.6	3.6		
7.8	3.6	2.4	1.8	
8.4	3.6	3.6	1.2	
9.0	3.6	3.6	1.8	
9.6	3.6	3.6	2.4	
10.2	3.6	3.6	1.8	1.2
10.8	3.6	3.6	3.6	
11.4	3.6	3.6	2.4	1.8
12.0	3.6	3.6	3.6	1.2

Total run in metres	Track lengths required					
12.6	3.6	3.6	3.6	1.8		
13.2	3.6	3.6	3.6	2.4		
13.8	3.6	3.6	3.6	1.8	1.2	
14.4	3.6	3.6	3.6	3.6		
15.0	3.6	3.6	3.6	2.4	1.8	
15.6	3.6	3.6	3.6	3.6	1.2	
16.2	3.6	3.6	3.6	3.6	1.8	
16.8	3.6	3.6	3.6	3.6	2.4	
17.4	3.6	3.6	3.6	3.6	1.8	1.2
18.0	3.6	3.6	3.6	3.6	3.6	
18.6	3.6	3.6	3.6	3.6	2.4	1.8
19.2	3.6	3.6	3.6	3.6	3.6	1.2
19.8	3.6	3.6	3.6	3.6	3.6	1.8

We recommend that no single run of Powertrack exceeds 20 metres.

UNDERFLOOR TO DESK SOLUTIONS

A high quality range of raised floor boxes to provide power and data to desks within the modern office environment. Available as standard or heavy duty versions, boxes are supplied with dividers for quick and easy configuration as either a 3 or 4 compartment box.

Designed with quality in mind, the standard support plate is 3mm thick and allows for high traffic levels. In the case of very heavy traffic a robust steel sub-frame can be used to support the lid. The sub-frame doesn't restrict space for wiring and accessories and also allows for fine adjustments to be made to accommodate uneven flooring.



Designed and manufactured to

- BS EN 61534-22:2009
- BS EN 60670-1:2005
- BS EN 60670-23:2008
- BS EN 50085-1:2005
- BS EN 50085-2-2:2008

Standard finish
GY
GY: Grey RAL7011 (floor box trim)



Barrel lock option for extra security



Optional steel sub-frame



Snap-in retainer guides



Reversible & self closing lid



Matching galvanised steel accessory plates

Dividers to create 3 or 4 compartment options

MT32 pre-wired option



UNDERFLOOR TO DESK SOLUTIONS

Product information

- Standard depth 83mm
- Supplied with dividers to create 3 or 4 compartment box
- Two earth fixing points for flexible positioning of sockets
- 3mm thick medium load plate
- Steel sub-frame option for heavy traffic and fine adjustment to allow for uneven flooring
- Supplied with two snap-in cable retainers/guides
- Grey trim as standard
- Cut-out within lid for carpet or carpet tiles up to 6mm
- Reversible lid

- Supplied with metal screws to fix attach trim to box for a secure fix
- Fixings are pre-punched for quick and easy installation
- Barrel lock option available for extra security
- RCD option
- Self closing lid for extra safety and security
- Pre-wired option available with MT32 Connectors
- Pre-wired boxes with tap-off
- Heavy duty steel galvanized conduit (BS EN 61386-23:2004+A11:2010)



Raised Floor Boxes

Other options

- Steel lid & trim option (UMLD3) for even greater strength and durability
- Lid (UMLD1) available separately
- Replacement cable flap (UMCB1) available separately
- Replacement screw pack (UMSC1) available separately



3 compartment standard floor box (terminal)
357 x 257 x 83mm

code	description	pack
UM1010	1 x 2 gang Std	1
UM1020	2 x 2 gang Std	1
UM1030	3 x 2 gang Std	1
UM1110	1 x 2 gang CE	1
UM1120	2 x 2 gang CE	1
UM1130	3 x 2 gang CE	1



3 Compartment standard floor box (through)
357 x 257 x 83mm

code	description	pack
UM5210	1 x 2 gang Std	1
UM5220	2 x 2 gang Std	1
UM5230	3 x 2 gang Std	1
UM5211	1 x 2 gang CE	1
UM5221	2 x 2 gang CE	1
UM5231	3 x 2 gang CE	1



4 compartment standard floor box (terminal)
357 x 257 x 83mm

code	description	pack
UM5010	1 x 2 gang Std	1
UM5020	2 x 2 gang Std	1
UM5030	3 x 2 gang Std	1
UM5110	1 x 2 gang CE	1
UM5120	2 x 2 gang CE	1
UM5130	3 x 2 gang CE	1



4 Compartment standard floor box (through)
357 x 257 x 83mm

code	description	pack
UM5610	1 x 2 gang Std	1
UM5620	2 x 2 gang Std	1
UM5630	3 x 2 gang Std	1
UM5611	1 x 2 gang CE	1
UM5621	2 x 2 gang CE	1
UM5631	3 x 2 gang CE	1



3 compartment standard pre-wired box with 3m tap-off
357 x 257 x 83mm

code	description	pack
UPW400	1 x 2 gang Std	1



3 compartment CE pre-wired box with 3m tap-off
357 x 257 x 83mm

code	description	pack
UPW405	1 x 2 gang CE	1



4 compartment standard pre-wired box with 3m tap-off
357 x 257 x 83mm

code	description	pack
UPW410	1 x 2 gang Std	1



4 compartment CE pre-wired box with 3m tap-off
357 x 257 x 83mm

code	description	pack
UPW415	1 x 2 gang CE	1



Tap-off (Standard) to MT32 connector

code	length	rating	pack
UN8113	3m	32Amp unfused	1
UN8115	5m	32Amp unfused	1
UN8123	3m	13Amp fused	1
UN8125	5m	13Amp fused	1



Tap-off (Clean Earth) to MT32 connector

code	length	rating	pack
UN8213	3m	32Amp unfused	1
UN8215	5m	32Amp unfused	1
UN8223	3m	13Amp fused	1
UN8225	5m	13Amp fused	1

MT32 Connectors

The description 'male' (white) and 'female' (black) does not refer to the connector pins but describes and identifies the moulded connector housings. For further information please contact our Technical Team on +44 (0)1424 856688.

UNDERFLOOR TO DESK SOLUTIONS



Empty floor box

code	description	pack
UM1000	Plastic lid & trim	1
UM1500	Steel lid & trim	1



Contractor floor box

code	description	pack
UM1430	Plastic lid/trim with plate to accept 1 x 2 gang accessory	1



Sub-frame assembly

code	pack
UMSF1	1



Lock kit

code	pack
UMLK1	1

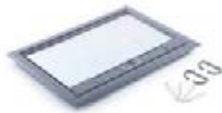

Raised floor lid assembly

code	description	pack
UMLD1	Plastic	1
UMLD3	Steel	1



Replacement screw pack

code	pack
UMSC1	1



Replacement cable flaps pack

code	pack
UMCB1	1



Slave unit (SU) 32Amp rating 100x100x55mm

code	description	pack
UM6100	4 way Std	1
UM6101	4 way CE	1

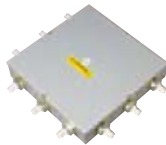

Master distribution unit (MDU) 32Amp rating 260 x 260 x 55mm

code	description	pack
UM6200	9 way Std	1
UM6201	9 way CE	1



Floor grommet

code	description	pack
UTG1BK	without foam insert	1
UTG1GY	without foam insert	1



Floor grommet

code	description	pack
UTG2BK	with foam insert	1
UTG2GY	with foam insert	1



Floor power grommet

code	description	pack
UPG1BK	with foam insert	1
UPG1GY	with foam insert	1

Please note the floor box grommets are available in black BK (RAL9004) and grey GY (RAL7037).

A range of floor outlet boxes, fittings and plates in galvanised steel, with choice of PVC-U or steel ducting designed to be positioned within screed flooring.

Product information

- 3 and 4 compartments (boxes come with extra divider to make 4 compartments)
- Suitable for 65-85mm screed depth
Boxes for deeper floor screed available on request
- Box tray lid suitable for standard 6mm floor finishes
- For advice on box tray lids for non-standard floor finishes please contact our Technical Team
- Adjustable for box trim height
- Grey moulded carpet trim for floor outlet boxes
- Steel trims with various finishes available
- Universal junction box with integral, fully-reversible cable segregation

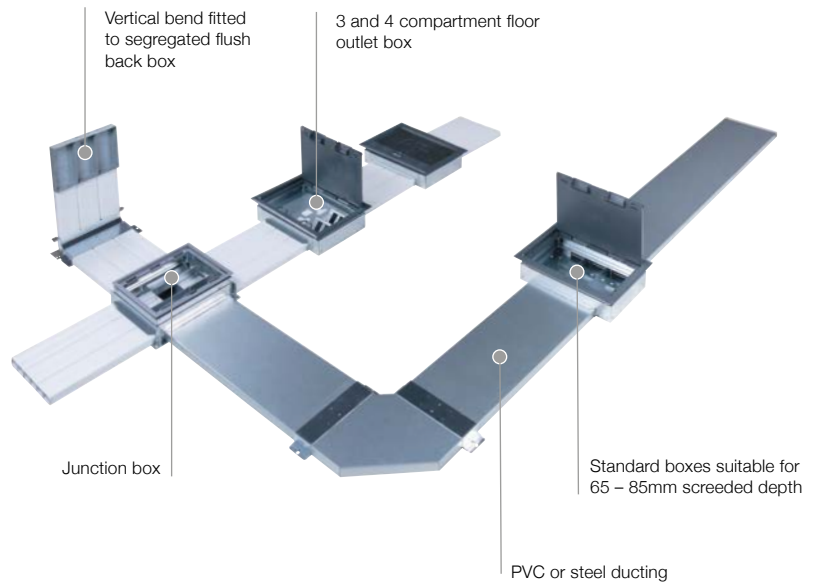

Standard floor box trim
GY
GY: Grey RAL7011 (floor box trim)

Other trim finishes: Floor boxes can be provided with a variety of trim finishes such as brass, stainless steel and painted colours. For further information please contact the Technical Team on +44 (0)1424 856688.

Basic components



**Floor outlet box
3 and 4 compartment**

code	size	pack
USF32	357 x 257mm	1



Floor box lid assembly

code	description	pack
UMLD1	Plastic	1
UMLD3	Steel	1

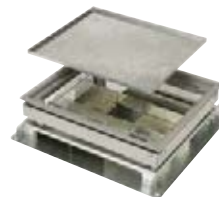

**Universal junction box
(excluding adaptors)**

code	size	pack
USJ3	269 x 234mm	1



**Twin section PVC-U duct
(three ducts required per run)**

code	size	pack
MTU125	75 x 25mm	8 x 3m

Please see page 14 for the full range of accessory plates



3 Compartment steel duct

code	description	pack
USFT25	225 x 25mm	1 x 2.5m



Blank end

code	description	pack
USFB1	3 x 20mm KO	1
USFB25	6 x 25mm KO	1



Adaptor

code	pack
USFA1	1



Connector

code	pack
USFC1	1

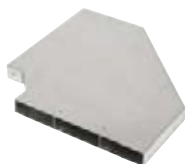

**Flat bend
(excluding connector)**

code	description	pack
USFF1	steel	1
HFP125BK	PVC-U	1



**Vertical bend
(excluding connector)**

code	description	pack
USFV1	steel	1
HVP125	PVC-U	1



Steel screeding plate

code	pack
USFSP1	1

Note: Used in place of box lid when screeding

Floor materials

Marshall-Tufflex can supply floor outlet boxes and junction boxes that are suitable for different floor materials, such as marble, stone or wood, or where a higher IP rating is required. For more information on these, please contact our Technical Team on +44 (0)1424 856688.



UNDERFLOOR TO DESK SOLUTIONS

MT32 pre-wired underfloor distribution is a prefabricated wiring system that incorporates 32Amp plug and play connector technology. The system provides a range of pre-wired, pre-tested products which can be used alone or in conjunction with powertrack, desk modules and other pre-wired systems to accommodate various underfloor layout options.



Product information

- Distribution from powertrack supply
- 32Amp power distribution
- Standard and CE systems
- Greater scope in layout design
- Wider range of floor distribution
- Economical and practical for large or high density floor areas
- Designs, dimensions and cable capacities to meet the latest BS EN ISO standards and accommodate all building designs and construction parameters
- Accessory plates manufactured from galvanised steel to match floor boxes

Plate dimensions

- 3 compartment 185 x 95mm
- 4 compartment 185 x 71mm



Standard finish
GY
GY: Grey RAL7011 (floor box trim)

MT32 Connectors

The description 'male' (white) and 'female' (black) does not refer to the connector pins but describes and identifies the moulded connector housing. For further information please contact our Technical Team on +44 (0)1424 856688.

UNDERFLOOR TO DESK SOLUTIONS

Components



Slave unit (SU)
32Amp rating
100 x 100 x 55mm

code	description	pack
UM6100	4 way Std	1
UM6101	4 way CE	1

MT32 Four compartment floor boxes

Terminal: Refer to page 83



Floor box – through 3 compartment
357 x 257 x 83mm

code	description	pack
UM5210	1 x 2 gang Std	1
UM5220	2 x 2 gang Std	1
UM5230	3 x 2 gang Std	1
UM5211	1 x 2 gang CE	1
UM5221	2 x 2 gang CE	1
UM5231	3 x 2 gang CE	1



Floor box – terminal 3 compartment
357 x 257 x 83mm

code	description	pack
UM1010	1 x 2 gang Std	1
UM1020	2 x 2 gang Std	1
UM1030	3 x 2 gang Std	1
UM1110	1 x 2 gang CE	1
UM1120	2 x 2 gang CE	1
UM1130	3 x 2 gang CE	1



Interconnecting conduit assembly To MDU, SU, FBDU and floor boxes

code	length	description	pack
UC3353	3m	Std	1
UC3355	5m	Std	1
UC4453	3m	CE	1
UC4455	5m	CE	1



***Male & female adaptors 220mm tail - fits 20mm knockout**

code	description	pack
UA7234	3 pole (male) white	1
UA7244	4 pole (male) white	1
UA7134	3 pole (female) black 1	1
UA7144	4 pole (female) black 1	1

*For adapting additional equipment and floor boxes to modular system.

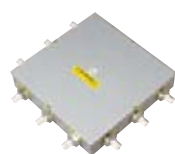

Master distribution unit (MDU) 32Amp rating
260 x 260 x 55mm

code	description	pack
UM6200	9 way Std	1
UM6201	9 way CE	1



Tap-off (Standard) to MT32 connector

code	length	rating	pack
UN8113	3m	32Amp unfused	1
UN8115	5m	32Amp unfused	1
UN8123	3m	13Amp fused	1
UN8125	5m	13Amp fused	1



Tap-off (Clean Earth) to MT32 connector

code	length	rating	pack
UN8213	3m	32Amp unfused	1
UN8215	5m	32Amp unfused	1
UN8223	3m	13Amp fused	1
UN8225	5m	13Amp fused	1

Suggested layout

Should powertrack be the preferred method of underfloor power supply, then combining powertrack with MT32's interlinked through floor boxes and/or slave units will provide a far greater reach of floor area than can be achieved using powertrack alone.

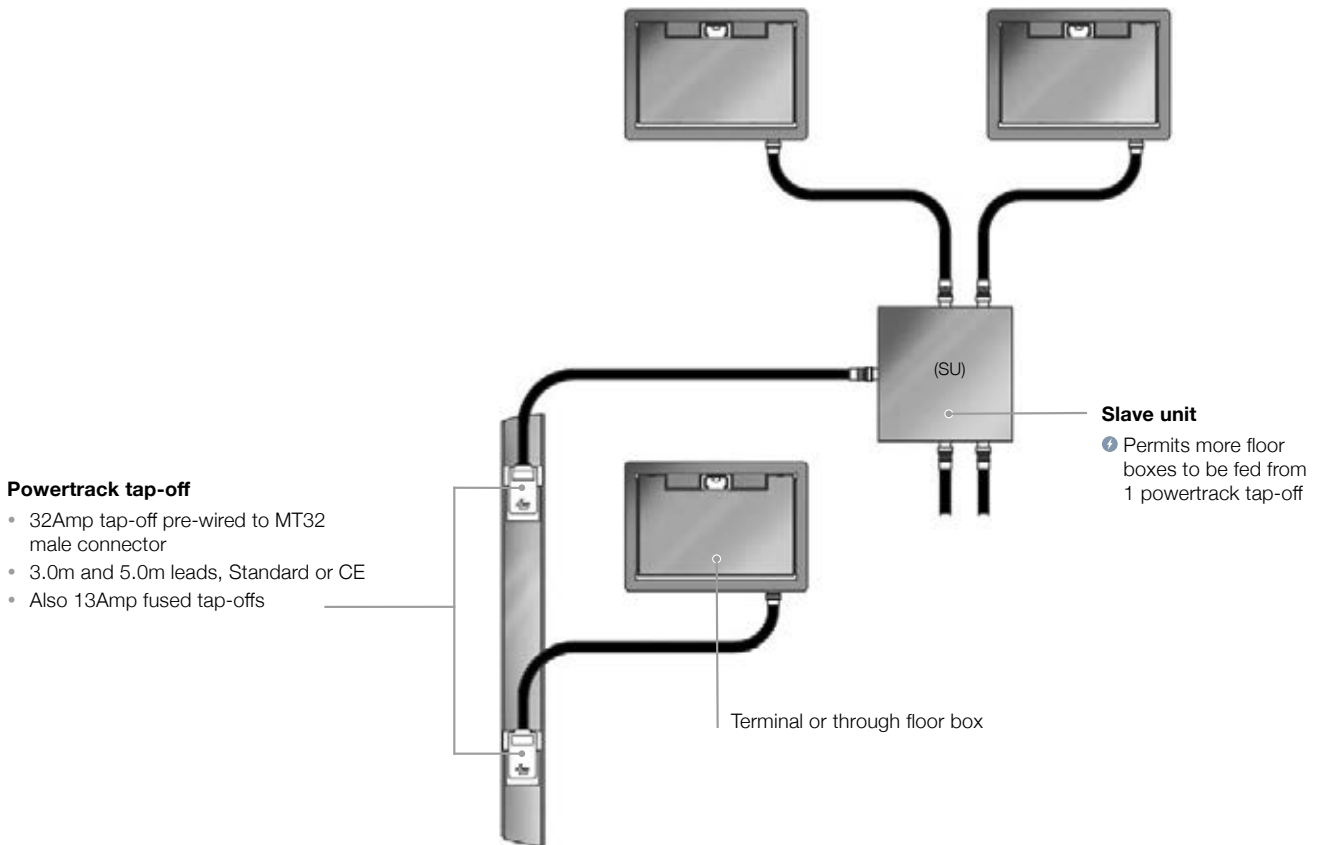



13Amp 2 gang DP/TE switched socket

code	description	pack
UP651	3 comp	1
UP751	4 comp	1



13Amp 2 gang DP/TE switched socket clean earth

code	description	pack
UP653	3 comp	1
UP753	4 comp	1



Double plate with 2 x 13Amp 2 gang switched socket

code	description	pack
UP751D	4 comp	1
UP753D	4 comp CE	1

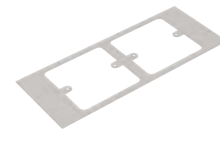

Plate to accept 2 x 1 gang accessory (M3.5 x 60.3mm)

code	description	pack
UP633	3 comp	1

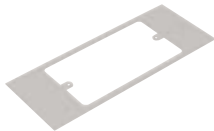

Plate to accept 1 x 2 gang accessory (M3.5 x 120.3mm)

code	description	pack
UP632	3 comp	1



Plate to accept 1 x 1 gang accessory

code	description	pack
UP631	4 comp	1



Plate to accept 1 x 1 gang accessory

code	description	pack
UP731	4 comp	1

Plate dimensions

3 compartment = 185 x 95mm
4 compartment = 185 x 71mm

Plate material

Plates are manufactured from plain galvanised steel to match floor boxes.



Plate to accept 2 x 1 gang accessory (M3.5 x 60.3mm)

code	description	pack
UP733	4 comp	1

Accessory overlaps adjacent plates

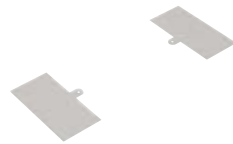

Plate to accept 1 x 2 gang accessory (M3.5 x 120.3mm)

code	description	pack
UP732	4 comp	1

Accessory overlaps adjacent plates



13Amp 2 gang RCD unswitched socket

code	description	pack
UP660	3 comp Std	1
UP663	3 comp CE	1



Blank plate

code	description	pack
UP621	3 comp	1
UP721	4 comp	1



Euro plate 2 gang

code	description	pack
UP615	3 comp	1
UP715	4 comp	1

Adaptor plate required 2 x 50mm x 50mm cut outs
Note: Adaptor plates are not supplied by Marshall-Tufflex

International accessory plates

It is advisable to use MTOP plates for conversion to a range of continental sockets. Please refer to page 232 of our main catalogue for more information.



Data/voice plate 6 x RJ45

code	description	pack
UP612	3 comp	1
UP712	4 comp	1

6 x 37mm x 22mm cut outs



Data/voice plate 4 x RJ45

code	description	pack
UP610	3 comp	1
UP710	4 comp	1

4 x 37mm x 22mm cut outs



Data wave plate 4 x RJ45

code	description	pack
UP617	3 comp	1

4 x 37mm x 22mm cut outs



Data wave plate 2 x RJ45

code	description	pack
UP717	4 comp	1

2 x 37mm x 22mm cut outs

A range of surface mounted power and data modules for use with office furniture.



Product information

- Flip up units - flush finish when in use
- Surface units - desk mounted
- Desk grommets
- Fed from wall trunking or floor boxes
- Various switching and fusing options available
- Individually fused
- Master switch option
- RCD and MCB protection available



Various configurations of power and data outlets

Aluminium body

Surface units

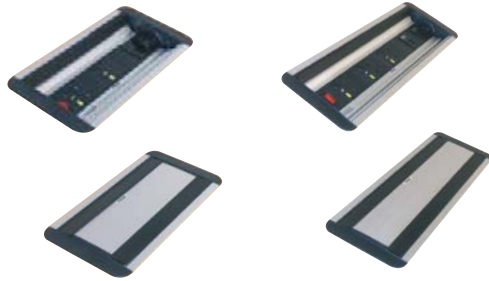

Flip-up unit with master switch and individually fused sockets

code	description	pack
FDMF002BK	2 gang	1
FDMF007BK	4 gang	1
FDMF008BK	5 gang	1

Flip-up unit with master switch, data outlets and individually fused sockets

code	description	pack
FDMF013BK	2 gang + 1 Cat 5e	1
FDMF014BK	3 gang + 2 Cat 5e	1
FDMF015BK	4 gang + 2 Cat 5e	1



Curved surface unit with master switch and individually fused sockets

code	description	pack
FDMC003BK	2 gang	1
FDMC005BK	3 gang	1
FDMC009BK	4 gang	1
FDMC011BK	6 gang	1



Curved surface unit with master switch, data outlets and individually fused sockets

code	description	pack
FDMC012BK	2 gang + 1 Cat 5e	1
FDMC013BK	3 gang + 2 Cat 5e	1
FDMC014BK	4 gang + 3 Cat 5e	1
FDMC015BK	4 gang + 4 Cat 5e	1
FDMC016BK	6 gang + 4 Cat 5e	1



13Amp in-feed power cable Wieland connector

code	length	pack
DM8301	1m	1
DM8302	2m	1
DM8303	3m	1

Please note that these products come with 2 x adjustable desk clamps (to suit between 13 - 40mm)



Desk grommet

code	diameter	pack
DG1BK	92mm	1

UNDERFLOOR TO DESK SOLUTIONS

p24 Technical Information

A range of power and data modules ideal for under desk mounting.



Product information

- High strength, flame retardant polycarbonate moulded modules
- Aluminium RCBO units
- Aluminium power modules
- Can be fed from wall trunking, floor boxes, grommets or powerpoles
- For single use or modules can be interlinked
- In-feed supply either by Wieland GST 18/3 connection or plug socket
- Unswitched individually fused 3.15Amp or 5Amp sockets
- 2 and 4 gang options plus the ability to link modules
- Polycarbonate power modules with twin USB points that charge up to 5 x faster than your standard PC USB port
- Desk units comply with BS 6396 for Electrical Systems in Office Furniture when powered from a plug socket outlet and with BS 7671 when powered from a power distribution network.
- RJ45 data sockets in Cat 5e, Cat 6 or blank configuration options

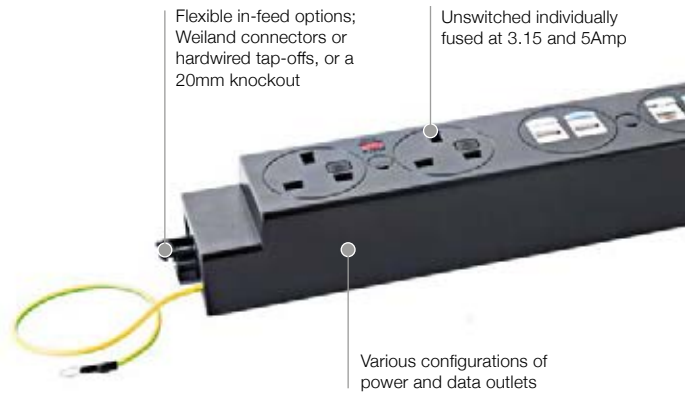

Our range of power modules and RCBOs can be integrated to deliver a complete system from underfloor to desk.

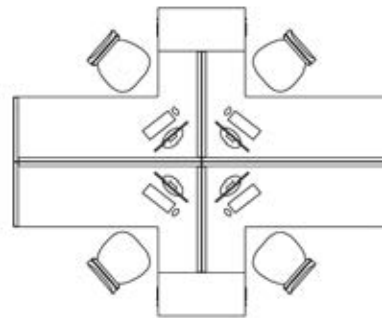
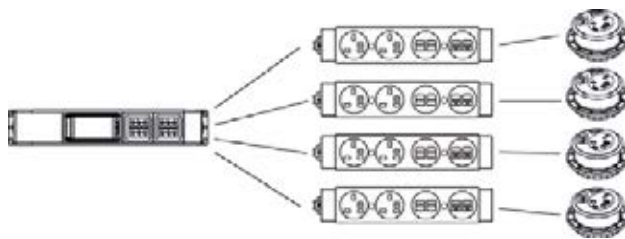

UNDERFLOOR TO DESK SOLUTIONS

Polycarbonate power modules



Power module 2G indiv fused		
code	description	pack
DM5001	3.15Amp	1
DM5003	5Amp	1

Power module 4G indiv fused		
code	description	pack
DM5002	3.15Amp	1
DM5004	5Amp	1

Aluminium power modules



Power module 4G STD (Terminal) For use with up to 13Amp supply		
code	description	pack
DM6003	3.15Amp	1
DM6005	5Amp	1

Power module 4G CE (Terminal) For use with up to 13Amp supply		
code	description	pack
DM6009	3.15Amp	1
DM6010	5Amp	1

Power module 4G STD (Terminal) For use with up to 32Amp supply		
code	description	pack
DM6002	3.15Amp	1
DM6004	5Amp	1

Power module 4G CE (Terminal) For use with up to 32Amp supply		
code	description	pack
DM6007	3.15Amp	1
DM6008	5Amp	1

All modules are supplied with 20mm knockout for power input

Aluminium power modules



NEW

**Power module 4G
STD & 13Amp tap-off**

code	description	pack
DM6013	3.15Amp 3m tap-off	1
DM6019	3.15Amp 5m tap-off	1
DM6015	5Amp 3m tap-off	1
DM6020	5Amp 5m tap-off	1



NEW

**Power module 4G
CE & 13Amp tap-off**

code	description	pack
DM6023	3.15Amp 3m tap-off	1
DM6029	3.15Amp 5m tap-off	1
DM6025	5Amp 3m tap-off	1
DM6030	5Amp 5m tap-off	1



NEW

**Power module 4G
STD & 32Amp tap-off**

code	description	pack
DM6012	3.15Amp 3m tap-off	1
DM6022	3.15Amp 5m tap-off	1
DM6014	5Amp 3m tap-off	1
DM6024	5Amp 5m tap-off	1



NEW

**Power module 4G
CE & 32Amp tap-off**

code	description	pack
DM6017	3.15Amp 3m tap-off	1
DM6027	3.15Amp 5m tap-off	1
DM6018	5Amp 3m tap-off	1
DM6028	5Amp 5m tap-off	1

Polycarbonate power & data modules



**Module 2xpower 2xUSB
2xCat 5e**

code	description	pack
DM5030	3.15Amp	1
DM5033	5Amp	1



**Module 2xpower 2xUSB
2xCat 6**

code	description	pack
DM5031	3.15Amp	1
DM5034	5Amp	1



**Module 2xpower 2xUSB
2xblank**

code	description	pack
DM5032	3.15Amp	1
DM5035	5Amp	1

UNDERFLOOR TO DESK SOLUTIONS

Desk Module USB

Power and Data Modules with Twin USB Fast Charger

With 5Amp output across two USB ports, our Power and Data Modules can simultaneously charge two devices at speeds comparable to, or faster than, the devices' own chargers.

- Fast charge 2 devices
- 5 Amps combined maximum output
- Up to 91% efficiency
- 5000+ USB insertion connections

The USB ports are designed to withstand the elements of a commercial environment with connectors built to withstanding over 5000 insertions.

This feature allows you to charge your devices faster, with far less power wastage through heat generation, and comply with the latest international standards on the efficiency of power supplies.



Aluminium RCBO16A/30mA units



RCBO 1xGST18 Female & tap-off STD

code	length	pack
DM5050	3m	1
DM5051	5m	1



RCBO 1xGST18 Female & tap-off CE

code	length	pack
DM5052	3m	1
DM5053	5m	1



RCBO 4xGST18 Female & tap-off STD

code	length	pack
DM5054	3m	1
DM5055	5m	1



RCBO 4xGST18 Female & tap-off CE

code	length	pack
DM5056	3m	1
DM5057	5m	1



RCBO 1xGST18 Female

code	pack
DM5058	1



RCBO 4xGST18 Female

code	pack
DM5059	1

Both modules supplied with 20mm knockout for power input

Wieland power cables



GST18/3 F & 13A plug

code	length	pack
DM8301	1m	1
DM8302	2m	1
DM8303	3m	1



GST18/3 M/F lead

code	length	pack
DM8502	1m	1
DM8503	1.5m	1
DM8504	3m	1

MT32 Pre-wired underfloor power distribution

Singles cabling system

Extension, connection, adaptor and terminal cables

Cable Type	6491B (HO1Z-R) to BS 7211 (LS0H)
Size	4.0mm ² x 3 (PE) or 4.00mm ² x 4 (CE)
Connector Self Lock Retention	> 80N
Male/Female Connector Diameter	19.2mm
Terminal Block	6 x 4.0mm ²
Adaptor (4.0mm ²)	20mm

Underfloor Distribution System

Conduit assembly, tap off and adaptor

Cable Type	6491X (BASEC BS 6004 H07V-R)
Protective Earth (P.E)	4.0mm ² x 3 (Grey Plug)
Clean Earth (C.E)	4.0mm ² x 4 (Red Plug)
Protection: Conduit Assembly	25mm Steel flexible conduit (>1KN Tensile Load to BS EN 61386-23)
Protection: Tap Off	20mm Steel flexible conduit (>1KN Tensile Load to BS EN 61386-23)

General specification

Approvals: System	Designed to comply with BS 7671:2008 IEE Wiring Regulations
Approvals: Connector	Designed to comply with EN 61535:2009 (Fixed installation couplers for permanent connection)
Normal Voltage	250 volts
Frequency	50/60 Hertz
Volt Drop Line & Neutral Connector	1.0 mV/A/M
Volt Drop Line & Neutral (Flexible Cabling System) 2.5mm	19.0 mV/A/M
Volt Drop Line & Neutral (Underfloor) 4.0mm	12.0 mV/A/M
Connector Impedance	1.0m Ω/connector
Connector, Body Material	PA66 – GF25
Connector Colour Female	Black
Connector Colour Male	White
Compatibility	Keyed against incorrect insertion
Operating Temperature (Ambient)	-5°C to + 40°C
Safety	PE contact engages first
Degree of Protection	Engaged IP2XC

Earthing requirements for the installation of equipment having High Protective/Conductor currents. BS 7671: 2008

Reg. 543.7

The scope of Reg. 543.7.1.203 requires that every final circuit intended to supply one or more items of equipment, where the total protective conductor current is likely to exceed 10mA. in normal use, shall have a high integrity protective connection.

Singles Cabling System 4.0mm²

Final Circuit

MT32 singles systems conform to the high integrity protective requirement by virtue of having a single copper protective conductor of 4mm², (Reg 543.7.1.203) with the protective conductor being enclosed throughout in trunking or flexible conduit to provide additional protection against mechanical damage.

Note: Different key ways apply between 2.5mm² and 4.0mm²

Installation

MT32 pre-wired socket range

Fitting

- Plug in incoming pre-wired lead (from previous socket or distribution board) to appropriate connector mounted in socket assembly box.
- Connect selected pre-wired lead to outgoing connector mounted on opposite side of socket assembly box.
- Clip complete assembly into trunking compartment.
- When trunking cover is fitted, it should be slid between back box frame and the loosened accessory face plate.
- Front plate is then fully tightened down to clamp accessory in place.
- For pre-made close coupled assemblies, use lid spacer (ES1WH) between boxes.

MT32 system with non-Marshall-Tufflex socket assemblies

Fitting

- For non-Marshall-Tufflex accessories, use pre-assembled outlet box unit.
- Connect cable tails to accessory in accordance with wiring regulations and fit accessory to back box.
- Connect pre-wired incoming and outgoing leads and fit to trunking (as above).
- For close coupled assemblies, use lid spacer (ES1WH) between boxes.

Powertrack

Powertrack is an underfloor busbar system rated at 63Amp maximum. It is available in Standard or CE (Clean Earth) versions.

Lengths

- Powertrack lengths of 1.2m, 1.8m, 2.4m and 3.6m with tap-off outlets at 300mm

Safety

- Snap-fit feed units, couplers and tap-offs are key and colour-coded to avoid assembly errors.



Standard = grey



CE = red

- A shutter is operated on insertion to prevent accidental contact.
- Avoid exceeding the maximum power rating of the track. This is ascertained by the maximum power requirement for each floor outlet box

Positioning

- For the most economic format, it is advised that Powertrack is arranged in parallel runs with Powertrack feed units orientated to the incoming supply.
- For optimum layout flexibility, spacing should be a maximum of 5.5m between each length of track and 2.5m from the perimeter when using a standard 3m tap-off to a floor box.

Installation

- Lay out track lengths and feed unit as required to suit final assembly
- Position and secure the feed unit in place
- Carefully engage the first track length on to the feed unit socket
- Ensure the clip action is secure at the coupler and unit feed also that alignment is correct in laying the track length to the floor
- Secure the track length in place along its length at recommended spacing shown below using the brackets provided
- Additional track lengths can now be placed as below.
- Ensure the assembly is secure and prepare to make electrical connections

Please refer to the full installation instructions, EL182 available at www.marshall-tufflex.com or by contacting the Technical Team on +44 (0)1424 856688.

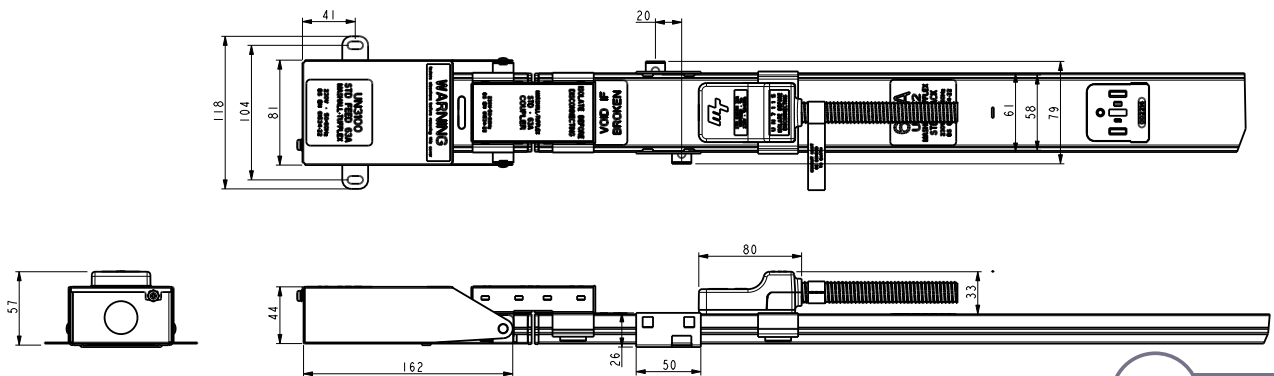
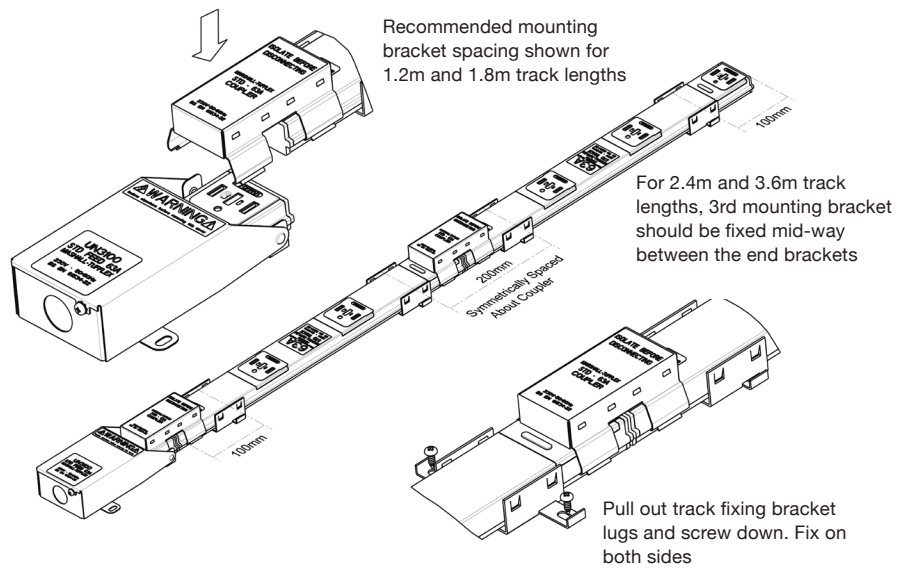

Electrical Characteristics			
Rated Current		63	Amps
Rated Voltage		230	Volts
Frequency		50/60	Hz
Conditional Short Circuit Rating	(Protection device: BS 1361 fuse)	16	KA
Conductor Resistance Line & Neutral		4.4	mΩ/m
Volt Drops Line & Neutral	Powertrack	4.4	mV/A/m
	Feed Unit + Coupler	2.2	mV/A
	Tap-Off	0.73	mV/A
	4mm ² Cable	11.0	mV/A/m
	Coupler	1.5	mV/A
	Interlink Unit	4.5	mV/A
	16mm ² Cable (1.2m)	3.9	mV/A/m
Earth Fault Loop Impedance:	Line to Earth (Casing)	2.8	mΩ/m
	Line to Earth (Conductor)	3.2	mΩ/m
	Line to Earth (Conductor + Casing)	2.8	mΩ/m
	Feed Unit + Coupler	2.2	mΩ
	Tap-Off	0.73	mΩ
	4mm ² Cable	11.0	mΩ/m
	Coupler	1.5	mΩ
	Interlink Unit	4.5	mΩ
	16mm ² Cable	3.9	mΩ/m
Mechanical Data			
Number of Copper Conductors		2 or 3	
Conductor Cross-section Area	Nominal	20	mm ²
Powertrack Casing Copper Equivalent	(Where casing is protective Earth)	12	mm ²
Cable Termination Capacity		16	mm ²
Tap-Off Cable 32A		4.0	mm ²
Tap-Off Cable 13A or 16A		4.0	mm ²
Tap-Off Conduit Sizes	Rating: Heavy duty conduit <1KN Tensile Load to BS EN 61386-23	Ø20	mm
Flexible Interlink Cable		16	mm ²
Flexible Interlink Conduit	Rating: Heavy duty conduit <1KN Tensile Load to BS EN 61386-23	Ø25	mm
Feed Conduit Entry		1 x Ø25	mm
IP Rating		40	
Minimum void depth (track + tap-off)		59	mm
Materials specification			
Powertrack Casing	Galvanised Steel		
Conductors	High Conductivity Copper/brass		
Powertrack Insulators	PBT		
Sockets/Tap-Off Plug/Joint Mouldings	Polycarbonate		
Shutter	PBT		
Tap-Off/Interlink Flexible Conduit	Galvanised Steel		
Tap-Off Cable	BASEC BS 6004 H07V-R		
Tap-Off/Coupler Blade	Copper		
Feed Unit Case	Galvanised Steel		
Flexible Interlink Cable	BASEC BS 6004 H07V-R		
Feed/Flexible Interlink Housing	Galvanised Steel		

Technical Specifications

Third party certified and tested to comply with:

BS EN 61534-1: 2011

BS EN 61534-22: 2009

BS 5733: 1995 where applicable.

Marshall-Tufflex is registered by BSI to BS EN ISO 9001: 2008

MT Powertrack is designed to comply with the requirements of BS 7671: 2008 (IEE Wiring Regulations).

ASTA Test Certification

Powertrack is independently tested by Intertek to BS EN 61534-22:2009 clauses 15.4, 18.4.3.2, & 18.4.3.3

Regulation 543.7

Installations to BS 7671:2008

Earthing requirements for the installation of equipment having high protective/ conductor currents.

The scope of Reg. 543.7.1.203 requires that every final circuit intended to supply one or more items of equipment, where the total protective conductor current is likely to exceed 10mA. in normal use, shall have a high protective connection.

All MT Powertrack tap-off units conform to the high integrity protective requirement by virtue of using a protective conductor of 4mm² enclosed within a flexible conduit, thus providing additional protection against mechanical damage. Regulation 543.7.1.203.

32Amp 3 metre tap-off unit

The 32Amp tap-off unit comprises of an unfused tap-off* a flexible metal conduit with integral 4mm² conductors.

These units are designed to comply with regulation 434.2.1(i) of BS 7671:2008 by virtue of the following:

- 1 Maximum length of cable is <3 metres.
- 2 Minimum risk of faults as the item is factory assembled and fully tested.
- 3 Fully protected by flexible steel conduit located within raised access floor that offers further protection.

*Fused 3 metre tap-offs are available if required.

5 metre tap-off unit

Tap-off units in excess of 3 metres should only be used if they contain a fuse or the powertrack is protected by a 32Amp rated protective device.

Raised floor boxes

Three and four compartment boxes and a range of grommets that can be configured to meet client requirements for accessing multiple services concealed below a raised floor system.

Technical specifications

Raised floor boxes are third party tested to comply with:

- BS EN 61534-22:2009
- BS EN 60670-1:2005
- BS EN 60670-23:2008
- BS EN 50085-1:2005
- BS EN 50085-2-2:2008

Material

- Lid/trim: flame retardant polypropylene grey RAL 7011
- Box assembly: galvanised steel
- Load plate: 3mm zinc plated steel
- Accessory plate: galvanised steel

Installation

- Box module has 20 and 25mm knockouts (pre-wired options available).
- Mounting plates:
3 compartment = 185 x 95mm
4 compartment = 185 x 71mm
- Standard accessory mounting plates available depending on suitability of floor box configuration.
- Cable covers protect cables when lid is closed.
- Detailed installation instructions are supplied in box.

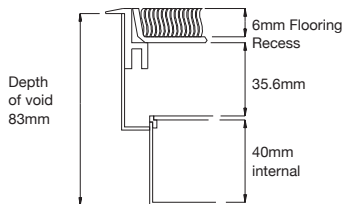

Dimensions

- For dimensions of non standard boxes and trims, contact Technical Hotline on +44 (0)1424 856688.

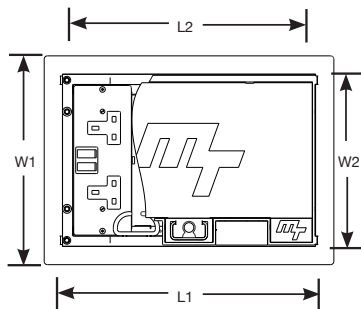

Dimensions

No of compartments	Nominal trim size (L1 x W1)	Cut out dimensions (L2 x W2)	Accessory Plate Dimensions
3	357 x 257mm	322 x 222mm	185 x 95mm
4	357 x 257mm	322 x 222mm	185 x 71mm
General tolerance +3mm			

Care should be taken to ensure that box edges are smoothed and free from burrs. Carpet tile cut size for lid is 303 x 166mm.

Load testing

Load testing of floor boxes to:

- BS EN 61534-22:2009
- BS EN 50085-2-2:2008

The floor boxes have been tested to and comply with the loading requirements of the aforementioned standards.

There are two loading criteria for the floor boxes:

- A point loading; to simulate foot traffic or light furniture like a chair leg / caster sitting on the lid. The maximum permissible deflection is 6mm (BS EN 61534-22:2009 and BS EN 50085-2-2:2008)
- A plate loading; to simulate heavy foot traffic or larger furniture loads. the maximum permissible deflection is 4mm (BS EN 61534-22:2009) or 6mm (BS EN 50085-2-2:2008)

Note: The maximum permissible permanent deflection after the load has been removed is 3mm for both standards.

The loading graphs show the deflection based on floor boxes without and with a sub-frame. The point loading value is approaching 1/4 of a metric tonne without sub-frame and reaching 1/4 of a metric tonne with sub-frame. In both cases the permanent deflection is less than 1/4 mm.

For plate loading without sub-frame the value is approaching 1/4 of a metric tonne with 4mm deflection and 1/3 of a metric tonne with 6mm deflection. With the sub-frame fitted the loading reaches 1/4 of a metric tonne with 4mm deflection and 1/2 a metric tonne with 6mm deflection. In both cases the permanent deflection is reaching 0.5mm.

Note: floor boxes fitted with sub-frame can exceed more than 1 metric tonne plate load before lid failure. In all tests (with and without sub-frame) the required loading was reached without damage to the plastic trim or compromised the lid.

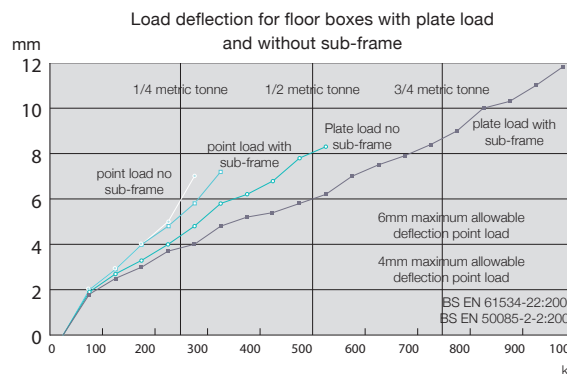
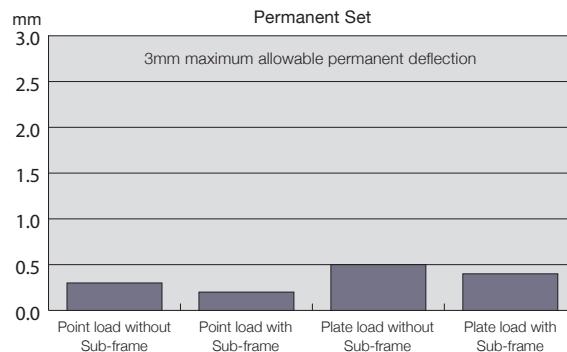

TECHNICAL INFORMATION

Grommets

Material

- ABS Flame retardant
- Flammability: UL94 V-0 at 2.0mm
- Colour: polypropylene grey RAL 7011
- Lid: captive screwdown
- Lid recess: 15mm for extra strength
- Through power/data options

Dimensions

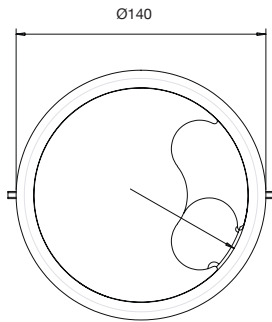

Cut out dimensions

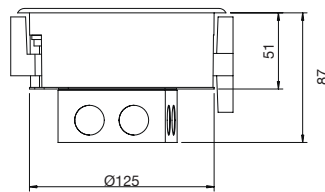

In-screed system

Three and four compartment boxes configured to meet client requirements for accessing multiple services concealed within an in-screed floor system.

Standard system is suitable for screed depths of 63mm to 85mm. For other screed depths please contact the Technical Team on +44 (0)1424 856688.

Material

- Lid/trim: polypropylene grey RAL 7011
- Frame assembly: galvanised steel
- Modular boxes: galvanised steel
- Load plate: galvanised steel

Installation

- Layout planning essential as alterations are not possible once screed is laid.
- Place floor boxes and junction boxes in position with top of boxes level and in line with expected finished floor level, with the sub-frame raised 10mm.
- Adjust boxes to screed depth by adjusting sub frame height.
- When boxes are in correct position, use PVC-U or steel duct to link between.
- To use conduit for linking boxes, utilize the Ø20mm knockout in the blank plate.

- Floor boxes can only be used as through boxes.
- Junction boxes have all round access with internal segregation.
- Duct adaptors and blank ends are not supplied for junction and service boxes. These must be ordered separately to individual requirements.
- Use a connector to join lengths of ducting.
- Flat and vertical bends or junction boxes are used where a change of direction is required.
- An optional steel screeding plate (USFSP1) is available to replace the box lid temporarily when screeding the floor.

Wiring accessories and mounting plates

- 3 compartment box: 185 x 95mm
- 4 compartment box: 185 x 71mm
- For use with standard 60.3mm and 120.6mm accessories with blank or pre-punched plates for data/telecoms etc.

Desk units

Flip up units

- Units have bi-directional access and are suitable for installation to BS 6396.
- Up to 4 x individually fused 3.15 sockets.
- Up to 4 x data outlets.

Fitting

- Simple, secure ratchet with hidden screw fixing.

Desk cut out size

- 132 x 430mm.
- Unit casing depth 90mm from top surface of desk.
- It is recommended that at least 400mm is clear below the cut out to allow cables to move freely.
- Cut out width is constant (132mm).
- Cut out length (430mm) will vary according to order requirements.

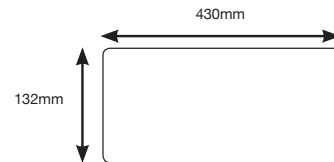

Junction box

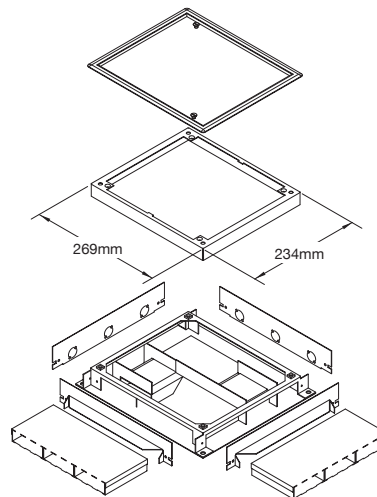

Floor outlet box

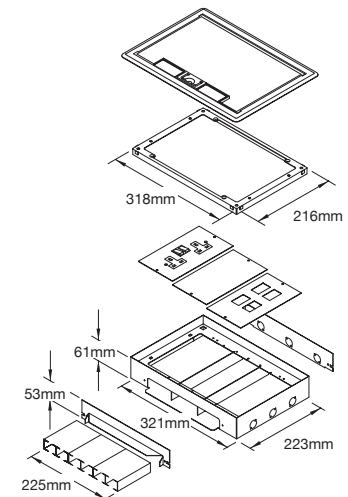

Box screed depth adjustment

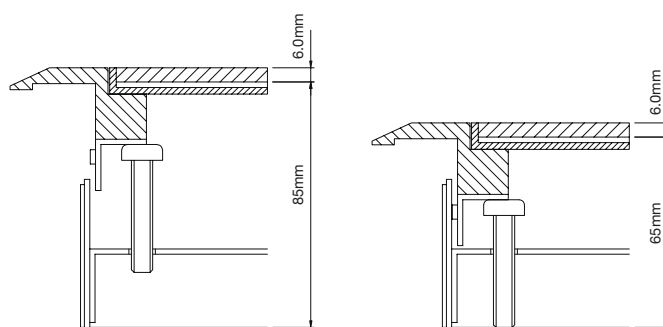

p11

Product Information

Desk grommets

Dimensions

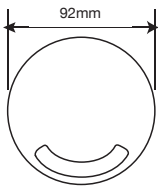

Cut out size

Box type	Diameter
DG1	80mm
General tolerance	2mm

Curved surface unit

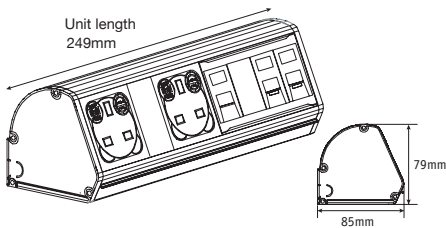

Adjustable desk clamp

Adjustable clamps suit desks from 5mm – 48mm thick.

- For use with curved surface units only.

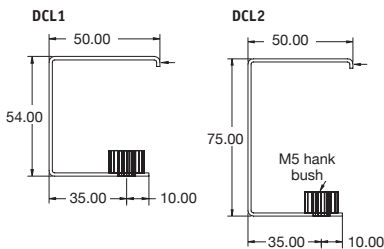

Power and data modules

Standards

- BS 1363-1
- BS 1363-2 (where applicable)
- BS 5733:2010+A1:2014
- EN 50581:2012
- EN 301 489-34(2012)
- IEC 60884-1:2005

For more information please contact our Technical Team on +44 (0)1424 856688.

Material

Power and Power and Data Modules are constructed from high strength flame retardant black polycarbonate mouldings. RCBO – constructed from aluminium casing.

Insulation

Reinforced insulation.

Earth Bonding:

- **Power Modules**
An external earth terminal allows connection of earth bonding leads without dismantling the unit. Please use suitable tools to cut earth lead from Power Modules if required.
- **Power and Data Modules**
Our Power and Data Modules units are supplied as standard with a prefitted 250mm earth lead to 5mm ring terminal.

Fusing

To enable compliance to BS 6396 the UK sockets are fitted with Ø5 x 20mm anti-surge ceramic fuses, with colour-coded fuse clips to denote the rating (3.15Amp or 5Amp).

RCBO rating

30mA 16Amp

Quality and testing:

100% testing – continuity, polarity, insulation & earth

- **Power and Data Modules only**
- USB charger: Output voltage and resistance
- Data & AV: All sockets continuity tested

Dimensions

Power modules

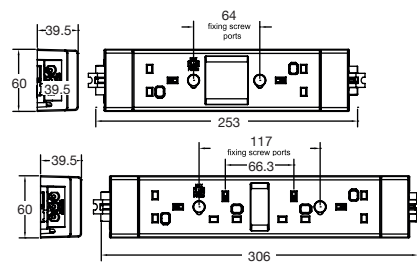

Power and data modules

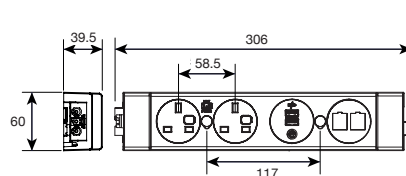

Configuration

- **Power modules**
Power only
- **Power and data modules**
2 x UK fused sockets plus 2 configurable gangs for Power, USB charging or data/AV
- **RCBOs**
Designed to be connected directly to underfloor track.
- Input connections via tap-off.
- Output connection via Weiland GST18/3.

Connection options

Power and Data Modules - Built in GST18/3 male for power in, plus optional GST18/3 female connector for power out on certain configurations.

Two modules units can be securely clipped together via the inbuilt GST18/3 connectors e.g. a DM5001 and DM5030 (both with 3.15Amp fuses) can be joined to form a BS 6396 compliant 6 socket unit.

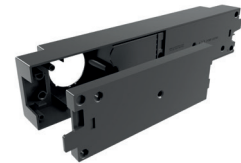

The rear section of the Power and Data Modules can be removed for onsite data/AV installation.

Cable type

In-feed power cable shown with optional Weiland connector.

- 13Amp rating
- Specification of cable length is necessary

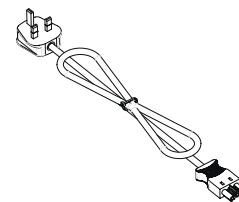

Power module earth lead

Size: 1.5mm²
Length: 250mm with 5mm ring terminal.

INTERNATIONAL DISTRIBUTORS

We distribute our cable management products to over 40 countries worldwide and welcome the opportunity to discuss any projects or requirements you may have. Below are the details of our main distributors around the world.



Bahrain
Amad Baeed Electrical W.L.L.
+973 1745 6590
sales@amadbaeed.com
www.amadbaeed.com



Cyprus
Andrews Electrical
+357 2249 0278
a.y@andrewselectrical.com.cy
www.andrewselectrical.net



Egypt
Light Import Establishment
+20 22291 1099
info@lightegy.com
www.lightegy.com



Gibraltar
A.J.Sheriff Electrical
+350 2006 1561
info@ajsheriffelectrical.com
www.ajsheriffelectrical.com



India
Vector Projects (I) Pvt. Ltd.
+91 226769 3312
gopi@vectorprojectsindia.com
www.vectorprojectsindia.com



Kuwait
Al-Dhow Engineering
+965 2291 5440
zoheb@al-dhow.com
www.al-dhow.com



Libya
Gamma Ltd
+218 21444 1653
moser@gamma.com.ly



Malaysia
Originex Electric Sdn Bhd
+60 37847 6882
koo@originex.com
www.originex.com



Malta
Calleja
+356 2144 0341
info@calleja.com.mt
www.calleja.com.mt



New Zealand
Ellis & Co Ltd
+64 09570 5267
info@ellis.co.nz
www.ellis.co.nz



Northern Ireland
Core Electrical Ltd
+44 28 900 200 66
info@coreelectrical.com
www.coreelectrical.com



Qatar
Mannai Trading Co. WLL
+974 4455 8888
info@mannai.com.qa
www.mannai.com



Republic of Ireland
Core Electrical Ltd
+353 1453 7033
info@coreelectrical.ie
www.coreelectrical.com



Russia
ICS Group
+7 495720 4900
ics@icsgroup.ru
www.icsgroup.ru



Saudi Arabia
HAWA Trading Est - Al-Khobar
+966 13 864 1464
farid@hawatrade.com
www.hawatrade.com



Saudi Arabia
HAWA Trading Est - Jeddah
+966 12 663 1268
hawajeddah@hawatrade.com
www.hawatrade.com



Sri Lanka
Bianco (Pvt) Ltd
+94 250 7252
bianco@sitnet.lk
www.bianco.lk



UAE
Titan GT FZC
+971 6740 6689
marshall-tufflex@titanuae.com
www.titanuae.com



If you would like to discuss distribution of our products worldwide, please email international@marshall-tufflex.com or telephone +44 (0)1424 856652



UK OWNED
UK MANUFACTURER

Marshall-Tufflex Ltd

Churchfields Industrial Estate
Hastings
East Sussex
TN38 9PU
United Kingdom

T +44 (0)1424 856600
F +44 (0)1424 856611
E sales@marshall-tufflex.com
www.marshall-tufflex.com

Technical Hotline:
+44 (0)1424 856688



Collect your order from our branches:

London (E17 6DJ)
Manchester (M26 1GG)
Hastings (TN38 9NU)

Republic of Ireland distributor

Core Electrical Ltd
17b Goldenbridge Industrial Estate
Tyrconnell Road, Inchicore
Dublin 8, D08 WD50

T +353 (0)1453 7033
F +353 (0)1453 8911

Northern Ireland distributor

Core Electrical Ltd
Unit 4 Duncrue Industrial Park
Duncrue Road
Belfast, BT3 9BP

T +44 (0)28 900 200 66
F +44 (0)28 900 213 08

In pursuance of our policy of continued product improvement Marshall-Tufflex reserve the right to change the design or specification of its products without notification.

